

INSTALLATION AND OPERATING INSTRUCTIONS

CAT. NO. KT-LED12T8-48G-BL-D

INSTALLATION

Product includes the following components:

PARTS	QUANTITY (Distributor Pack)	QUANTITY (Carton Pack)
LED Tube	1	25 pcs/box
Installation Instruction Sheet	1	1

CAUTION: Before installing, make certain the AC power to the fixture is off.

CAUTION: The electrical rating of this product is 120-277V. Installer must confirm that there is 120-277V at the fixture before installation.

CAUTION: LEDs are extremely bright. Do not look directly at the LED light source for extended time as over-exposure may cause harm to the eyes.

CAUTION: These lamps emit light in the UV-A Light spectrum (315-400nm) during operation.

Avoid prolonged and / or repeated exposure under light source and do not stare directly at the light source.

Exposure at less than 12" should be limited. Certain medications and chemicals can increase an individual's sensitivity.

Consult your physician for specific information. Protective eyewear should be worn in occupational situations involving long term exposure in close proximity to the lamp. This lamp is not intended and should not be used for diagnostic therapeutic or cosmetic purposes.

Installation Steps

Removing Existing Fluorescent System

1. Disconnect power from fixture.
2. Remove fluorescent lamp(s).
3. Remove lens and wiring compartment, if applicable.
4. Cut all wires connected to the ballast as shown below and remove ballast.

Typical Ballast Configurations

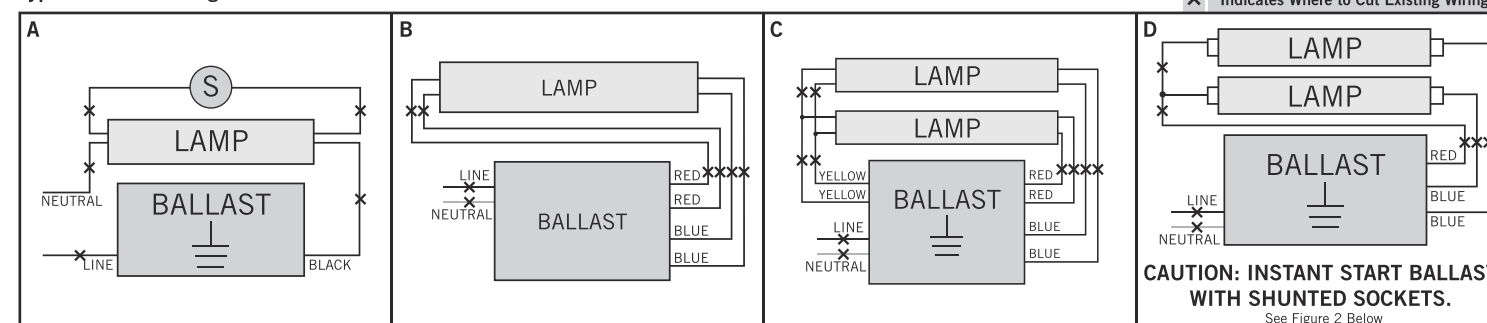

5. Identify what type of lampholders are in fixture. Direct Drive LED Tubes require non-shunted G13 medium bi-pin lampholders.

CAUTION: Use only non-shunted lampholders. Do not install product in a fixture with shunted lampholders (found in all fixtures using instant start ballasts). If the existing lampholders are shunted, remove them and replace them with non-shunted lampholders (or remove the external shunt if applicable). Make new connections directly to lampholder terminals as shown in Figure 1 below.

Typical Non-Shunted Lampholder

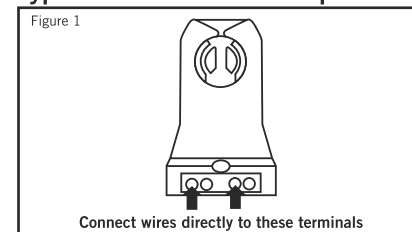

Typical Shunted Lampholders

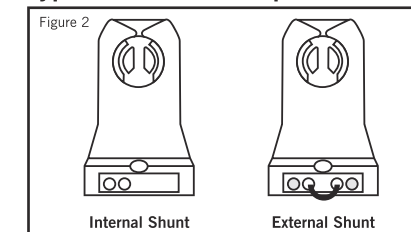

6. If applicable, replace lampholders with non-shunted lampholders.

KT-LED12T8-48G-BL-D

INSTALLATION AND OPERATING INSTRUCTIONS

Tube Installation

NOTE: Only one end of this LED tube receives power. The powered end is indicated by a sticker on the Direct Drive LED tube itself and the endcap is marked with (L) for line and (N) for neutral.

1. Confirm that power is still disconnected from fixture.
2. Make sure fixture is properly grounded.
3. Follow step A for single lamp application or steps B&C for multiple lamp application, based on the number of lamps in the fixture:

Single Lamp

A. Connect line (L) and neutral (N) AC wires to the side of lampholder which corresponds to the (L) and (N) marked on the endcap. If only one lamp is being installed, proceed to step 4.

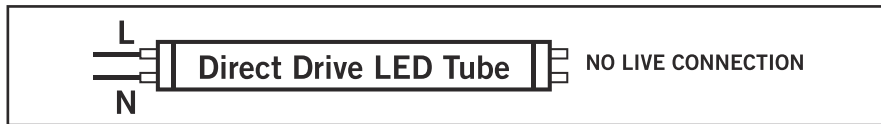

Multiple Lamps

- B. Follow the steps above for single lamp connection to connect the first lamp.
- C. Connect the terminals on the powered lampholder on the first lamp to the matching terminals on the powered lampholder on the second lamp with line and neutral wires as shown below. Continue daisy-chain connection for each additional lamp.

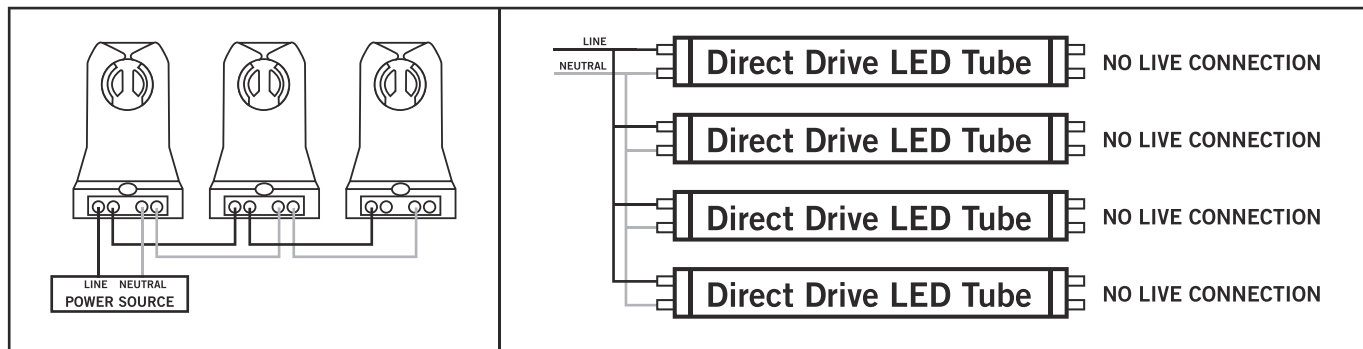

4. Complete all electrical connections with appropriate connectors/wire nuts as needed, per all local and national electrical codes.
5. Replace wiring compartment cover.
6. Install all of the Direct Drive LED tubes with the end marked for power connections installed in the lampholders wired to the line and neutral and with the LED's pointed in the proper direction for illumination. Install any lens or diffuser as applicable.
7. Apply power to fixture and check for illumination.

To comply with the published safety standards, the following must be observed when using this LED tube:

LED TUBE MODEL NO.	INPUT VOLTAGE	INPUT FREQUENCY	INPUT CURRENT	INPUT WATTAGE	TUBE LENGTH
KT-LED12T8-48G-BL-D	120-277V	50-60 Hz	135mA	12.5W	1198 mm

1. These LED tubes are intended for lighting systems only.
2. These LED tubes are for indoor use only. Maximum ambient temperature must not exceed 55°C (131°F).
3. Avoid use in sunlight, abnormal heat, or moist / condensing environments.
 - Working temperature : -20°C~55°C (-4°F~131°F)
 - Working humidity : 30%~85%
 - Storage temperature : -40°C~65°C (-40°F~149°F)
 - Storage humidity : 10%~90%
4. These LED tubes are not intended to be repaired by the user, manufacturer, or service personnell in any case of failure.
5. These LED tubes are constructed such that they do not rely upon the luminaire enclosure for protection against accidental contact with live parts.
6. These LED tubes are intended to retrofit a maximum of four lamps in a UL Listed, surface mount, type IC or non-IC, recessed mount fluorescent luminarie with or without diffuser that use straight tubular lamps.
7. These LED tubes are intended to be used in dry or damp locations only.
8. Do not use with dimmers
9. This device is not intended for use with emergency exits
10. These tubes are intended to be installed in the same orientation as the fluorescent tubes they are replacing.

KT-LED12T8-48G-BL-D

INSTALLATION AND OPERATING INSTRUCTIONS

WARNINGS

WARNING - RISK OF FIRE OR ELECTRIC SHOCK. LED RETROFIT KIT INSTALLATION REQUIRES KNOWLEDGE OF LUMINAIRES ELECTRICAL SYSTEMS. IF NOT QUALIFIED, DO NOT ATTEMPT INSTALLATION. CONTACT A QUALIFIED ELECTRICIAN.

AVERTISSEMENT - RISQUE D'INCENDIE ET DE DÉCHARGE ÉLECTRIQUE. L'INSTALLATION D'UN SYSTÈME DEL NÉCESSITE UNE CONNAISSANCE DES SYSTÈME ÉLECTRIQUES POUR LUMINAIRES. N'ENTREPRENEZ AUCUNE INSTALLATION SI VOUS N'ÊTES PAS QUALIFIÉ. CONTACTEZ UN ÉLECTRICIEN QUALIFIÉ.

WARNING - RISK OF FIRE OR ELECTRIC SHOCK. INSTALL THIS KIT ONLY IN THE LUMINAIRES THAT HAVE THE CONSTRUCTION FEATURES AND DIMENSIONS SHOWN IN THE PHOTOGRAPHS AND/OR DRAWINGS AND WHERE THE INPUT RATING OF THE RETROFIT KIT DOES NOT EXCEED THE INPUT RATING OF THE LUMINAIRE.

AVERTISSEMENT - RISQUE D'INCENDIE OU DE CHOC ÉLECTRIQUE. INSTALLER CE KIT SEULEMENT DANS DES LUMINAIRES QUI AYANT LES CARACTÉRISTIQUES DE CONSTRUCTION ET LES DIMENSIONS MENTIONNÉES DANS LES PHOTOGRAPHIES ET / OU LES DESSINS ET OÙ LA VÉRIFICATION D'ENTRÉE DU KIT RETROFIT NE DÉPLACE PAS LA VALEUR D'ENTRÉE DU LUMINAIRE.

DO NOT MAKE OR ALTER ANY OPEN HOLES IN AN ENCLOSURE OF WIRING OR ELECTRICAL COMPONENTS DURING KIT INSTALLATION

WARNING - TO PREVENT WIRING DAMAGE OR ABRASION, DO NOT EXPOSE WIRING TO EDGES OF SHEET METAL OR OTHER SHARP OBJECTS.

AVERTISSEMENT - AFIN D'ÉVITER TOUT DOMMAGE OU ABRASION AU SYTÈME DE CÂBLES, NE PAS EXPOSER CE DERNIER À DES BORDS DE PLAQUES EN MÉTAL OU À DES OBJETS TRANCHANTS.

WARNING: TO AVOID POTENTIAL FIRE OR SHOCK HAZARD, DO NOT USE THIS RETROFIT KIT IN LUMINAIRES EMPLOYING SHUNTED BI-PIN LAMPHOLDERS. NOTE: SHUNTED LAMPHOLDERS ARE FOUND ONLY IN FLUORESCENT LUMINAIRES WITH INSTANT-START BALLASTS. INSTANT-START BALLASTS CAN BE IDENTIFIED BY THE WORDS "INSTANT START" OR "I.S." MARKED ON THE BALLAST. THIS DESIGNATION MAY BE IN THE FORM OF A STATEMENT PERTAINING TO THE BALLAST ITSELF, OR MAY BE COMBINED WITH THE MARKING FOR THE LAMPS WITH WHICH THE BALLAST IS INTENDED TO BE USED, FOR EXAMPLE F40T12/IS. FOR MORE INFORMATION, CONTACT THE LED LUMINAIRE RETROFIT KIT MANUFACTURER.

AVERTISSEMENT - AFIN D'ÉVITER TOUT RISQUE D'INCENDIE OU DE DÉCHARGE, NE PAS UTILISER CE SYSTÈME POUR DES LUMINAIRES UTILISANT DES DOUILLES DE LAMPE BI-CONTACTS COURT-CIRCUITÉES. NOTE : LES DOUILLES DE LAMPE BI-CONTACTS COURT-CIRCUITÉES SE TROUVENT GÉNÉRALEMENT DANS LES LUMINAIRES FLUORESCENTS AVEC BALLASTS À ALLUMAGE INSTANTANNÉ. CES DERNIERS S'IDENTIFIENT PAR LES TERMES « INSTANT START » OU « I.S. ». CES TERMES PRENNENT LA FORME D'UN ÉNONCÉ RELATIF AU BALLAST MÊME OU PEUVENT ÊTRE AJOUTÉS AUX INDICATIONS CONCERNANT LES LAMPES AVEC LESQUELLES LES BALLASTS DOIVENT ÊTRE UTILISÉS (PAR EXEMPLE, F40T12/IS). POUR DE PLUS AMPLES RENSEIGNEMENTS, VEUILLEZ COMMUNIQUER AVEC LE FABRICANT DU SYSTÈME DE LUMINAIRE DEL.

INSTALLERS SHOULD NOT DISCONNECT EXISTING WIRES FROM LAMP HOLDER TERMINALS TO MAKE NEW CONNECTIONS AT LAMP HOLDER TERMINALS. INSTEAD INSTALLERS SHOULD CUT EXISTING LAMP HOLDER LEADS AWAY FROM THE LAMP HOLDER AND MAKE NEW ELECTRICAL CONNECTIONS TO LAMP HOLDER LEAD WIRES BY EMPLOYING APPLICABLE CONNECTORS.

THE RETROFIT KIT IS ACCEPTED AS A COMPONENT OF A LUMINAIRE WHERE THE SUITABILITY OF THE COMBINATION SHALL BE DETERMINED BY AUTHORITIES HAVING JURISDICTION. PRODUCT MUST BE INSTALLED BY A QUALIFIED ELECTRICIAN IN ACCORDANCE WITH THE APPLICABLE AND APPROPRIATE ELECTRICAL CODES. THE INSTALLATION GUIDE DOES NOT SUPERSEDE LOCAL OR NATIONAL REGULATIONS FOR ELECTRICAL INSTALLATIONS.

LUMINAIRE LORSQUE LA PERTINENCE DE LA COMBINAISON DOIT ÊTRE DÉTERMINÉE PAR LES AUTORITÉS COMPÉTENTES. CE PRODUIT DOIT ÊTRE MIS EN PLACE PAR UN ÉLECTRICIEN QUALIFIÉ CONFORMÉMENT AUX CODES ÉLECTRIQUES APPROPRIÉS APPLICABLES. LE GUIDE D'INSTALLATION NE SUPPLANTE PAS LES RÈGLEMENTS LOCAUX OU NATIONAUX EN MATIÈRE D'INSTALLATIONS ÉLECTRIQUES.

TYPE B LAMP – INTENDED FOR OPERATION IN LUMINAIRES WITH TRADITIONAL FLUORESCENT-TYPE LAMPHOLDERS WIRED DIRECTLY TO THE BRANCH CIRCUIT. THIS INCLUDES BOTH FACTORY-WIRED LUMINAIRES AS WELL AS THOSE CONVERTED FOR THIS PURPOSE UNDER A RETROFIT PROGRAM. CAUTION-RISK OF ELECTRLC SHOCK. DO NOT USE IF OUTER LAMP ENVELOPE IS DAMAGED OR BROKEN

ATTENTION - RISQUE DE CHOC ELECTRIQUE. NE PAS UTILISER SI LE BOÎTIER DE L'AMPOULE EST ENDOMMAGÉ OU ENDOMMAGÉ